

KVH Industries, Inc.

# TracPhone® V7

32" (82 cm) Configuration



## Installation Guide

This addendum applies to products with antenna serial number 110601833 or later.

# PLEASE READ!

## Important Addendum to Your Product Manual

A small packet of silicone grease is supplied in the kitpack. Apply this grease to the inner body of all RF cable connectors that you connect to the KVH antenna and any inline feed-thru adapters above deck. This grease will help prevent moisture from seeping into or forming inside the connector and protect the center conductor from corrosion.

Figure 1 Silicone Grease



### Directions for Use

When connecting RF cables above deck to the KVH antenna, as well as to any inline feed-thru adapters, follow the steps below to protect and seal each connection:

1. Clean and dry the male connector on the RF cable and the female connector on the antenna or feed-thru adapter.
2. Fill half of the inner body of the RF cable's connector with silicone grease. *Connecting the cable in the next step will displace the grease to fill the entire space within the connector.*
3. Connect and **SLOWLY** hand-tighten the RF cable to the antenna or feed-thru adapter, allowing the grease to diffuse and settle into the entire connector body.
4. Make sure the RF cable's connector is tightened all the way into the female connector of the antenna or feed-thru adapter. Then tighten the connection with a 7/16" torque wrench set to 15 in.-lbs.
5. Wipe off any excess grease from the outside of the connector.
6. Seal the connection with silicone sealant, self-vulcanizing tape, or equivalent. If using self-vulcanizing tape, be sure to wrap the tape **CLOCKWISE** around the connector (*the same direction in which you tightened the connector*). Wrapping the tape in the opposite direction will result in tension that might loosen the connector over time.

The procedure is complete.

# TracPhone V7 Installation Guide

## KVH's Complete mini-VSAT Broadband<sup>sm</sup> System

These instructions explain how to install the TracPhone V7 mini-VSAT Broadband satellite communications system. Instructions on how to use the system are provided in the *User's Guide*.

---

### Installation Steps

- |   |    |                                      |    |
|---|----|--------------------------------------|----|
| 1. Inspect Parts and Get Tools .....      | 3  | 10. Wire the Belowdecks Units.....   | 14 |
| 2. Plan the Antenna Installation .....    | 4  | 11. Connect Power .....              | 16 |
| 3. Plan the Belowdecks Installation ..... | 5  | 12. Configure the Computer(s) .....  | 18 |
| 4. Prepare the Belowdecks Units.....      | 6  | 13. Turn On the System.....          | 21 |
| 5. Prepare the Antenna Site.....          | 9  | 14. Update the System Software ..... | 22 |
| 6. Prepare the Antenna .....              | 10 | 15. Set Up RF Hazard Zones.....      | 23 |
| 7. Wire the Antenna .....                 | 11 | 16. Test the System.....             | 24 |
| 8. Mount the Antenna .....                | 12 | 17. Educate the Customer .....       | 26 |
| 9. Remove the Restraints .....            | 13 |                                      |    |

---

### CAUTION - RF Radiation Hazard



The antenna transmits radio frequency (RF) energy that is potentially harmful. Whenever the system is powered on, make sure everyone stays more than 36 feet (11 m) away from the antenna within its 5-80° elevation range. No hazard exists directly above the antenna and anywhere below the antenna's mounting plane.

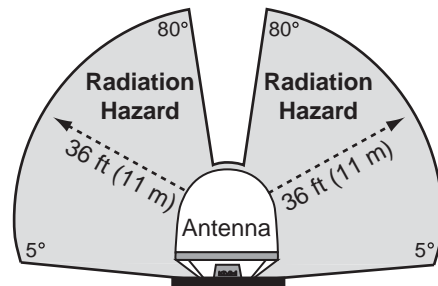

---

### Who Should Install the System?

To ensure a safe and effective installation, only a KVH-certified technician should install the TracPhone system. KVH-certified technicians have the tools and electronics expertise necessary to install the system. To find a technician near you, visit [www.kvh.com/wheretogetservice](http://www.kvh.com/wheretogetservice).

---

### Technical Support

**North/South America, Australia:**

Phone: +1 401 847-3327

E-mail: [V7Support@kvh.com](mailto:V7Support@kvh.com)

**Europe, Middle East, Asia, Africa:**

Phone: +45 45 160 180

E-mail: [support@kvh.dk](mailto:support@kvh.dk)

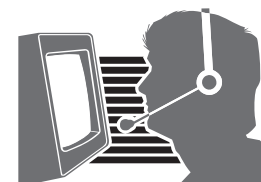

KVH, TracPhone, and the unique light-colored dome with dark contrasting baseplate are registered trademarks of KVH Industries, Inc. All other trademarks are property of their respective companies. The information in this document is subject to change without notice.

No company shall be liable for errors contained herein. © 2008-2011 KVH Industries, Inc., All rights reserved. **54-0523 Rev. D**

U.S. Patent Pending

# 1 Inspect Parts and Get Tools

Before you begin, follow these steps to make sure you have everything you need to complete the installation.

- a. Unpack the box and ensure it contains everything shown in Figure 1 and on the *Kitpack Content Lists*. Save the packaging for future use.

**IMPORTANT!**

Always lift the antenna by the baseplate and never by the radome or any portion of the internal antenna assembly (see Figure 1).

- b. Carefully examine all of the supplied parts to ensure nothing was damaged in shipment.
- c. Gather all of the following tools and materials that you will need:
  - Flat-head and Phillips-head screwdrivers
  - Electric drill and 1/2" (13 mm) bit
  - 2" (50 mm) hole saw
  - Wire cutters, wire strippers, and terminal lug crimper
  - Socket wrenches and extension
  - 11/16" open-end or box wrench, and 7/16" open-end wrench
  - Silicone sealant or self-vulcanizing tape
  - Light hammer and center punch
  - Adhesive tape and scribe or pencil
  - Two RF coax cables and F-connector installation tools (see page 11)
  - Isolation transformer, if required (see page 16)
  - Windows® 7, Vista™, or XP laptop with the latest version of TPV7 Flash Update Wizard installed (software available to technicians on the KVH Partner Portal)

**NOTE:** KVH offers the optional KVH CommBox™ for connecting multiple communication systems to the onboard local area network (LAN), providing least cost routing, firewall, bandwidth management, web caching, and optimization features (KVH part #72-0470 (compact) or #72-0472 (rack-mount)).

Figure 1: TracPhone V7 System Components

**Antenna**

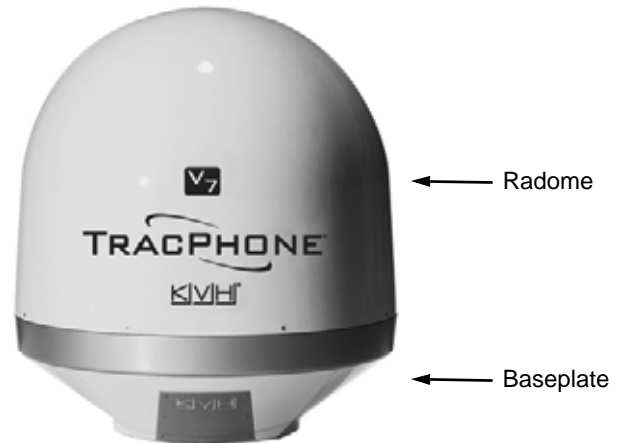

**Control Unit**



**Modem**



**Ethernet Switch**



**Multimedia Terminal Adapter (MTA)**



**Remote Service & Support Module**



# 2 Plan the Antenna Installation

Before you begin, consider the following antenna installation guidelines:

- Minimize blockage. The antenna requires a clear view of the sky to transmit and receive satellite signals (see Figure 2). The fewer obstructions, the better the system will perform.
- Make sure the mounting surface is wide enough to accommodate the antenna's base (see Figure 3). Also make sure it is flat, level, strong enough to support the antenna's weight (100 lbs, 45 kg), and rigid enough to withstand heavy vibration.
- Select a location that is as close as possible to the intersection of the vessel's centerline and midships.
- Select a location that is well above any areas accessible to passengers and crew to reduce the risk of RF radiation exposure.
- Avoid placing the antenna near any magnetic compasses or other onboard antennas to prevent potential interference.

**IMPORTANT!**

Do not mount the antenna at the same level as the radar because the radar's energy might overload the antenna and damage its internal components. Ideally, you should mount the antenna 4 ft (1.2 m) above the radar, outside the beam path of the radar.

Figure 2: Blockage from Obstruction

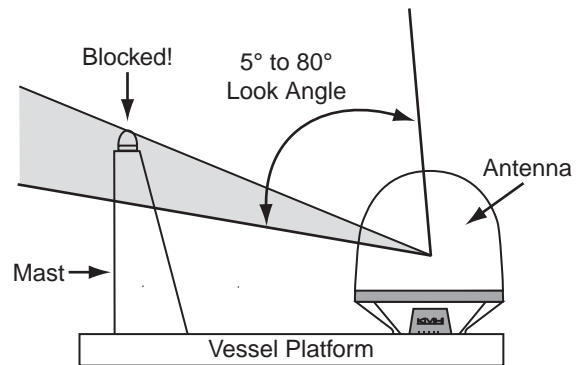
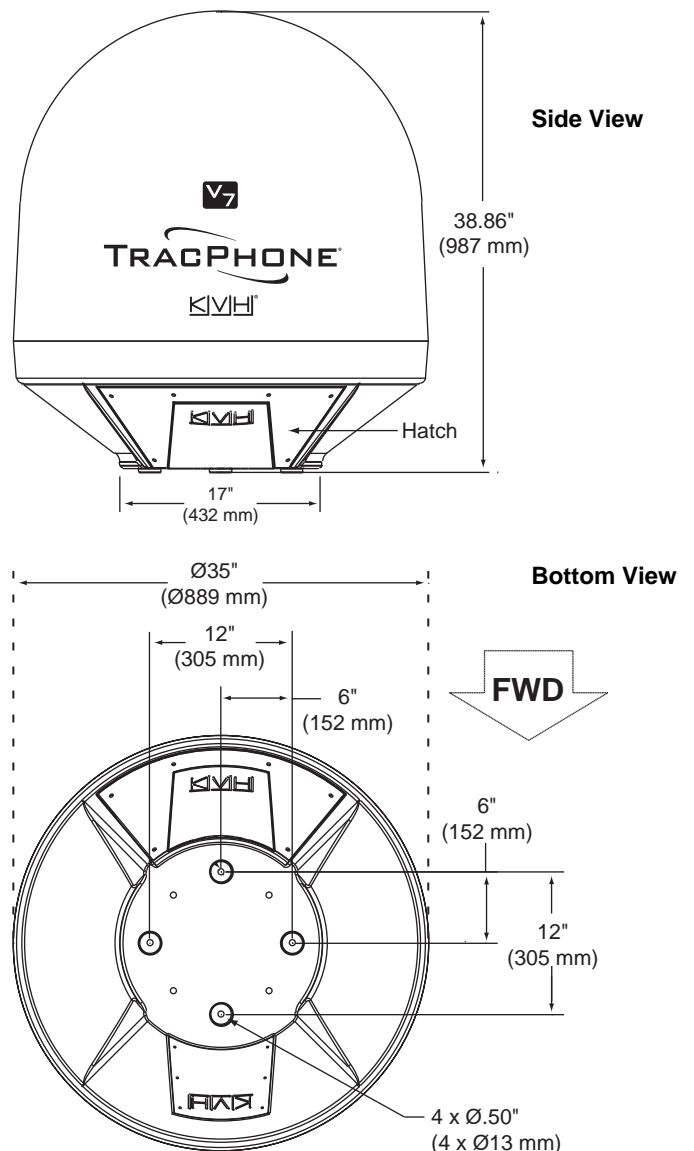

Figure 3: Antenna Dimensions



# 3 Plan the Belowdecks Installation

Before you begin, consider the following installation guidelines for the belowdecks units.

## Control Unit and Modem

- Select a mounting location in a dry, well-ventilated area belowdecks away from any heat sources or salt spray.
  - Be sure the front panels will be easily accessible to the user.
  - Leave enough room at the rear panel to accommodate the connecting cables.
  - You have several options for mounting the control unit and modem:
    - Option 1** - Inside the optional case
    - Option 2** - To a horizontal surface together using two L-brackets
    - Option 3** - To a horizontal surface separately using four L-brackets
- NOTE:** The control unit and modem are sized to fit a standard 19" (482.6 mm) equipment rack.
- To use the supplied data and power cables, the control unit must be located within 100 ft (30 m) of the antenna. However, you can order 150 ft (45 m) cables if a longer cable run is necessary (see Figure 18 on page 11).

## Switch and MTA

- To use the supplied Ethernet cables, select a mounting location within 25 ft (7.5 m) of the modem (maximum length = 200 ft (60 m)).
- If you install a wireless access point (*supplied by customer*), be sure the location provides adequate WiFi reception. Do not install it in an area surrounded by metal or near any electrical devices that emit RF noise.

## Remote Service & Support Module

- To use the supplied serial data cable, select a mounting location within 25 ft (7.5 m) of the control unit (maximum length = 50 ft (15 m)).
- Be sure the location provides adequate GPRS cellular reception.

Figure 4: Control Unit or Modem Dimensions (Identical)

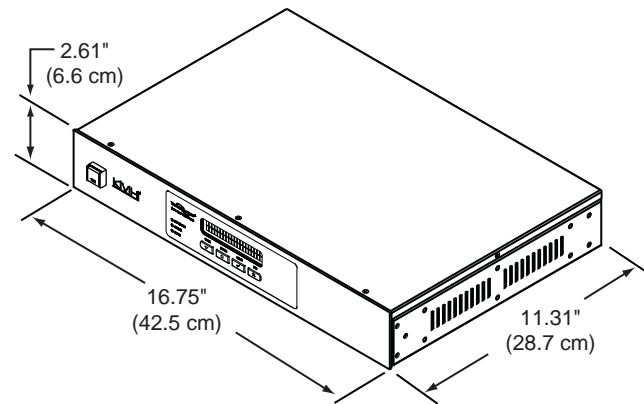

Figure 5: Case Dimensions

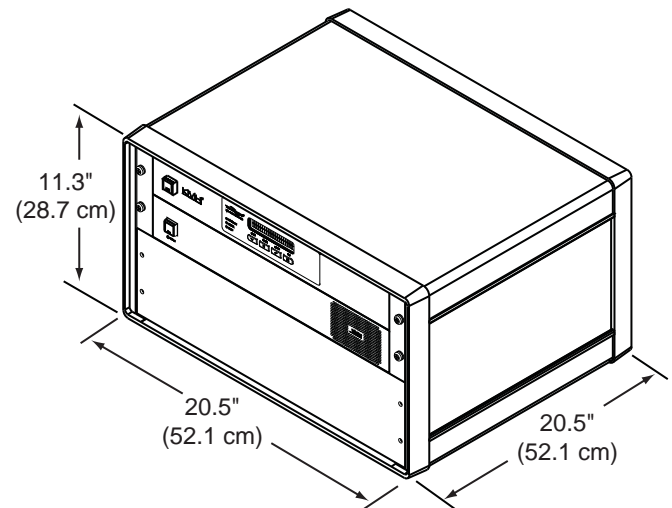

Figure 6: Dimensions of Ancillary Components

Component	Dimensions (W x D x H)
Switch	6.7" x 3.9" x 1.1" (17 cm x 9.9 cm x 2.8 cm)
MTA	4.6" x 5.12" x 1.18" (11.7 cm x 13 cm x 3 cm)
Remote Service & Support Module	5.12" x 3.54" x 1.5" (13 cm x 9 cm x 3.8 cm)

# 4 Prepare the Belowdecks Units

## Option 1 - Mounting in the Case

If you plan to mount the control unit and modem inside the optional 19" (482.6 mm) case, follow these steps to assemble the case.

- a. Remove the four M4 screws securing the rear cover to the case. Discard the rear cover.
- b. Attach the top cover to the case using four M4 x 12 mm screws (see Figure 7). Attach the bottom cover and the two mounting brackets using four M4 x 16 mm screws.
- c. Attach the four plastic feet to the bottom cover (see Figure 7).
- d. At the front of the case, insert eight cage nuts into the following locations on the frame (four on each side) (see Figure 7): #2, #5, #8, and #11.
- e. At the back of the case, insert four cage nuts into the following locations on the frame (two on each side): #1 and #3.
- f. Remove the four #6-32 screws and washers securing the two retaining straps to the rear panel of the control unit. *Do not remove the bottom screws securing the straps to the modem.*
- g. Attach the strain-relief bracket to the retaining straps and control unit using the screws and washers you removed in Step f (see Figure 8).
- h. At the top 3U section of the case, insert the control unit/modem assembly and secure the front mounting brackets to the case using four M6 screws and washers (see Figure 9).
- i. At the bottom 3U section of the case, attach the supplied blank panel using four M6 screws and washers (see Figure 9).
- j. Secure the back of the control unit to the back of the case using the two supplied "Z" brackets. Attach the brackets to the case frame using four M6 screws and washers. Attach the brackets to the rear panel of the control unit using four #6-32 screws and washers (see Figure 9).
- k. Once you have completed all system wiring, mount the case to the vessel using fasteners appropriate for the mounting surface.

Figure 7: Assembling the Case

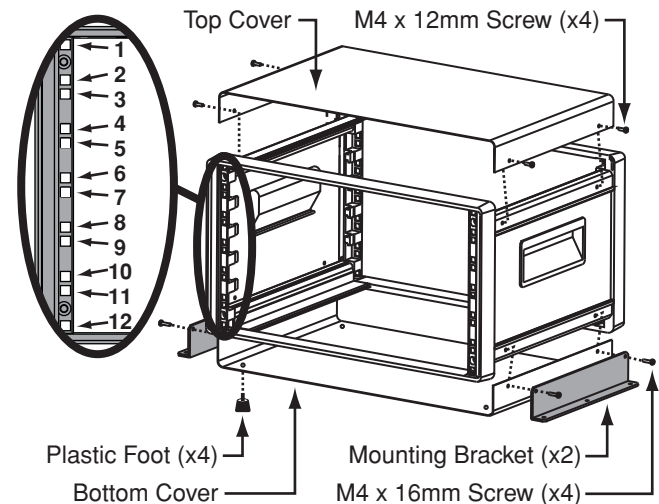

Figure 8: Attaching the Strain-Relief Bracket

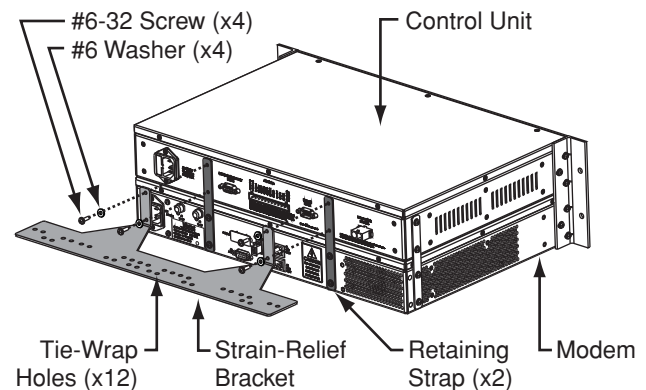
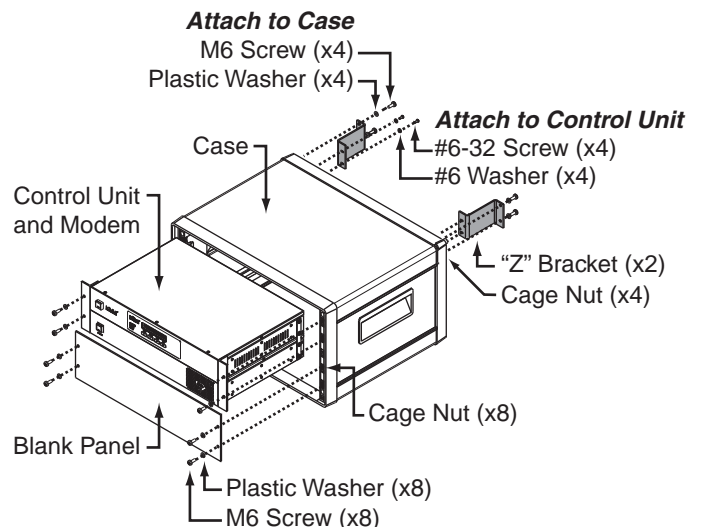

Figure 9: Securing the Control Unit/Modem in the Case



# 4 Prepare the Belowdecks Units

## Option 2 - Mounting Units Together

If you plan to mount the control unit and modem together as an assembly, without using the optional case or an equipment rack, follow these steps to attach the strain-relief bracket and “L” mounting brackets.

- a. Remove the four #6-32 screws and washers securing the two retaining straps to the rear panel of the control unit. *Do not remove the bottom screws securing the straps to the modem.*
- b. Attach the strain-relief bracket to the retaining straps and control unit using the screws and washers you removed in Step a (see Figure 10).
- c. Attach two of the supplied “L” mounting brackets to the sides of the control unit or modem using four #6-32 screws and washers (see Figure 11). You can attach the brackets to either the top of the control unit or the bottom of the modem, depending on your desired mounting location.
- d. Once you have completed all system wiring, mount the modem/control unit assembly to the vessel using fasteners appropriate for the mounting surface.

Figure 10: Attaching the Strain-Relief Bracket

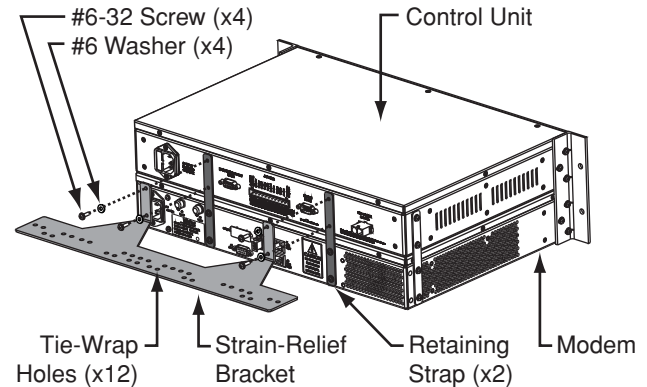
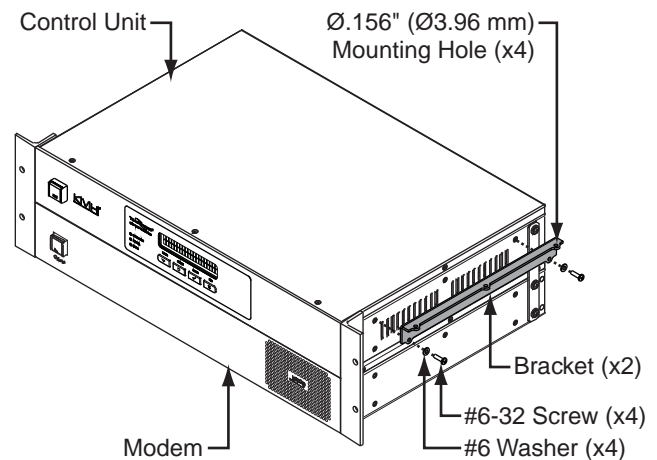

Figure 11: Attaching the Mounting Brackets





# 4 Prepare the Belowdecks Units

## Option 3 - Mounting Units Separately

If you plan to mount the control unit and modem separately, follow these steps to detach the control unit from the modem, attach the strain-relief brackets, and attach the “L” mounting brackets.

- a. Remove the 28 #6-32 screws and washers securing the two rack-mount brackets and four metal retaining straps to the control unit and modem (see Figure 12). Remove the brackets and straps.
- b. Attach a strain-relief bracket to the back of the control unit using four of the screws and washers you removed in Step a (see Figure 13).
- c. Attach a second strain-relief bracket to the back of the modem using four of the screws and washers you removed in Step a (see Figure 14).
- d. Attach two of the supplied “L” brackets to the sides of the control unit using four #6-32 screws and washers (see Figure 11 on page 7). You can attach the brackets at either the top or bottom of the control unit, depending on your desired mounting location.
- e. Attach the two other supplied “L” brackets to the sides of the modem using four #6-32 screws and washers (see Figure 11 on page 7). You can attach the brackets at either the top or bottom of the modem, depending on your desired mounting location.
- f. Once you have completed all system wiring, mount the control unit and modem to the vessel using fasteners appropriate for the mounting surface.

Figure 12: Detaching the Control Unit from the Modem

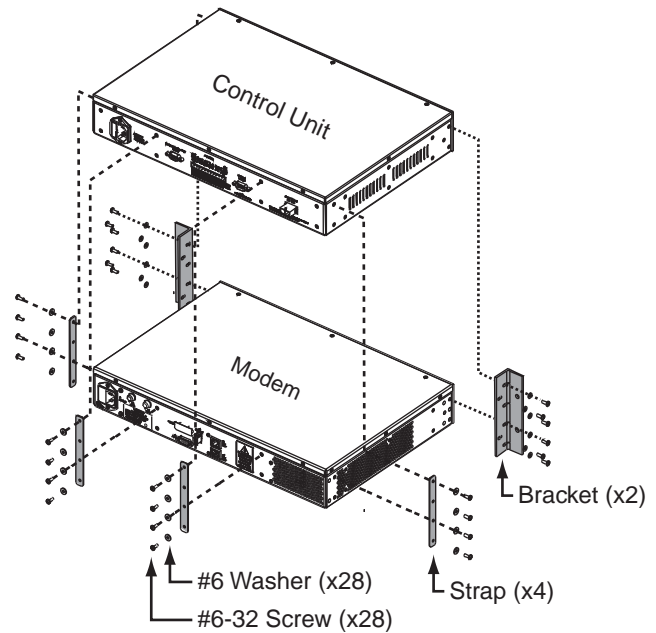

Figure 13: Attaching the Bracket to the Control Unit

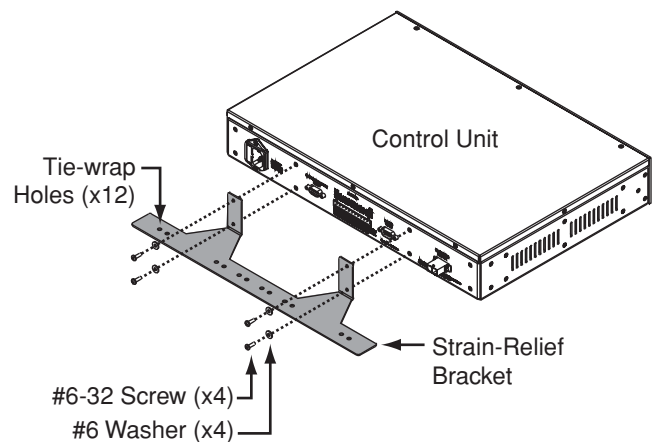
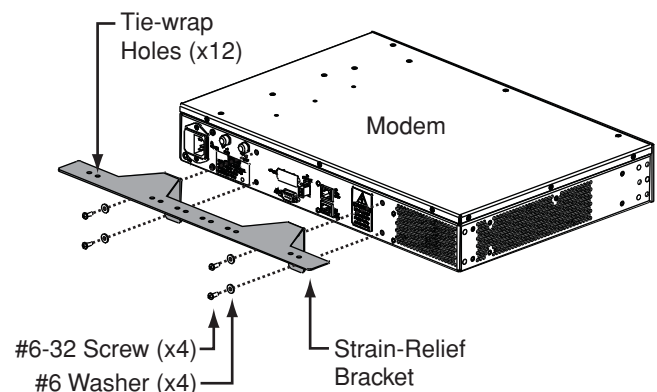

Figure 14: Attaching the Bracket to the Modem



# 5 Prepare the Antenna Site

Once you have identified a suitable antenna mounting site, according to the guidelines provided in Step 2, follow these steps to drill the mounting holes and cable access hole to prepare the site for installation.

- a. Unfold the antenna mounting template (supplied in the Customer Welcome Kit) and place it onto the mounting surface. Make sure the “FWD” (forward) arrow points toward the bow and is parallel to the vessel’s centerline (see Figure 15).

**NOTE:** You don’t need to mount the antenna exactly on the vessel’s centerline, but the antenna’s forward arrow must be parallel to it.

- b. Using a light hammer and center punch, mark the locations for the four mounting holes and cable access hole on the mounting surface in the locations indicated on the template.
- c. Drill a 1/2" (13 mm) hole at the four mounting hole locations you marked in Step b. Later, you will insert four M10 bolts from below to secure the antenna to the mounting surface.
- d. Cut out the 2" (50 mm) cable access hole in the location you marked in Step b. Smooth the edges of the hole to protect the cables. Later, you will route the data, power, and RF cables through this hole and into the vessel.
- e. Clean and dry the antenna mounting surface.
- f. Peel off the paper backing from the supplied foam seal to expose the adhesive. Then press the foam seal down firmly onto the mounting surface, ensuring the hole in the foam seal aligns with the cable access hole in the mounting surface (see Figure 15).

**NOTE:** Apply the foam seal to the vessel mounting surface, not to the antenna’s baseplate. You will have difficulty connecting cables to the antenna if the foam seal is attached to the baseplate.

Figure 15: Antenna Mounting Holes Layout

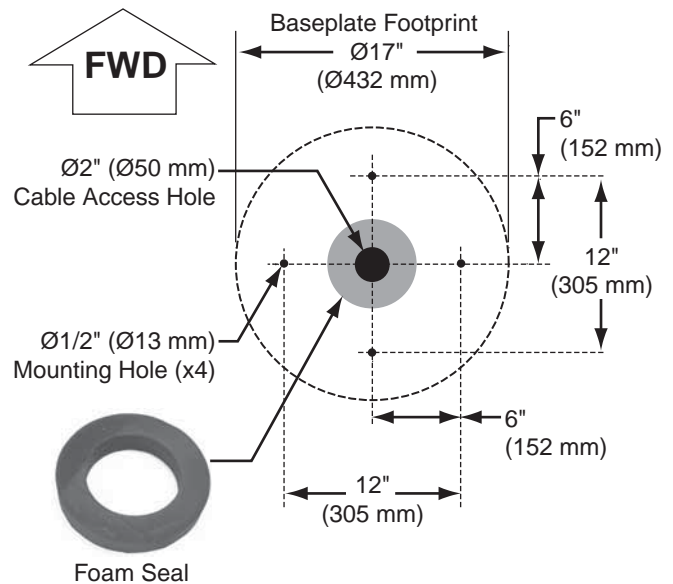

# 6 Prepare the Antenna

Follow these steps to remove the service hatch and radome. They must be removed before you can wire and mount the antenna.

- a. Remove the eleven M4 screws securing the service hatch to the antenna's baseplate (see Figure 16). Set the hatch aside in a safe place.
- b. Remove and save the two #10-32 Phillips screws securing the radome to the baseplate. (The six other radome screws are in the kitpack. You will use these later when you reinstall the radome.) Carefully lift the radome straight up until clear of the antenna assembly and set it aside in a safe place (see Figure 17).

**TIP:** If you keep the radome topside, secure it with a lanyard to prevent it from falling overboard.

Figure 16: Baseplate Service Hatch

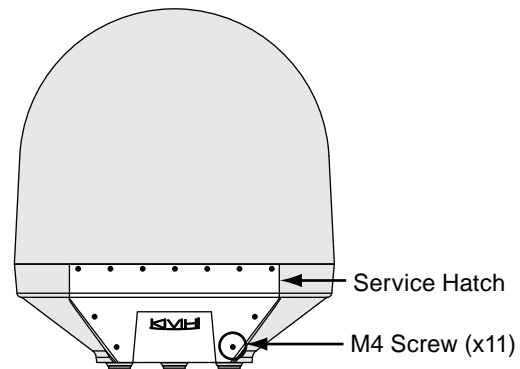
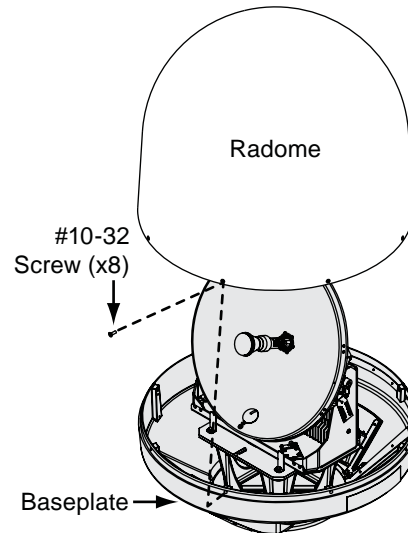

Figure 17: Removing the Radome



# 7 Wire the Antenna

Follow these steps to connect the antenna cables.

- a. In addition to the data and power cables, you will need to connect two 75Ω RF coax cables from the antenna to the belowdecks equipment. Use the guidelines in Figure 18 to determine the type of RF cables required.

**IMPORTANT!**

Terminate RF cables with the proper type “F” connectors (see Figure 18). Instructions for terminating LMR-400-75 cable are provided in Appendix B on page 30.

- b. **Label both ends** of the two RF cables. Label one cable “TX,” and label the other “RX.”
- c. Route the data, power, and RF cables belowdecks through the 2" (50 mm) cable access hole. Keep 2 ft (60 cm) of each cable outside the hole to allow enough slack to connect the cables and maintain a service loop inside the antenna.
- d. Insert the other ends of the cables up through the center hole in the bottom of the antenna’s baseplate.
- e. Connect the data cable to the “Data” jack on the bottom of the antenna assembly (see Figure 19). Hand-tighten until the connector locks in place; do not use excessive force.
- f. Connect the power cable to the “Power” jack on the bottom of the antenna assembly. Hand-tighten until locked in place.
- g. Connect the RF cable labeled “TX” to the “MTx” jack on the bottom of the antenna assembly. Hand-tighten, then tighten with a 7/16" wrench for 1/4 turn to ensure a good electrical connection.
- h. Connect the RF cable labeled “RX” to the “MRx” jack on the bottom of the antenna assembly. Hand-tighten, then tighten with a 7/16" wrench for 1/4 turn.
- i. Seal both RF cable connections with silicone sealant, self-vulcanizing tape, or equivalent.

Figure 18: RF Cable Requirements\*

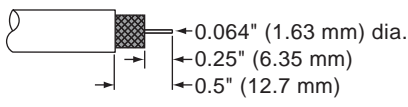
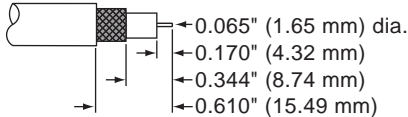
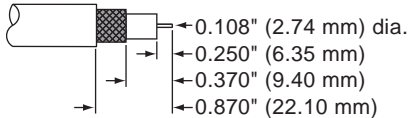
<p><b>15-50 ft (5-15 m) Cable Run</b></p> <p>Cable: RG-11</p>  <p>Connector: SNS11AS Installation Tools: CST596711 and L3011B</p>
<p><b>51-100 ft (16-30 m) Cable Run</b></p> <p>Cable: LMR-400-75</p>  <p>Connector: EZ-400-FMH-75 Installation Tools: TK-400EZ-75</p>
<p><b>101-150 ft (31-45 m) Cable Run</b></p> <p>Cable: LMR-600-75</p>  <p>Connector: EZ-600-FMH-75 Installation Tools: TK-600EZ</p>

\* For alternate cable options, see the Application Notes section of the KVH Partner Portal (technicians only).

**NOTE:** *RG-11 connectors/tools are manufactured by Thomas & Betts. LMR-400-75 and LMR-600-75 cables/connectors/tools are manufactured by Times Microwave.*

**NOTE:** *Optional 150 ft (45 m) data and power cables:  
Data cable KVH part #32-0921-0150  
Power cable KVH part #32-0924-0150*

Figure 19: Connectors on Bottom of Antenna Assembly

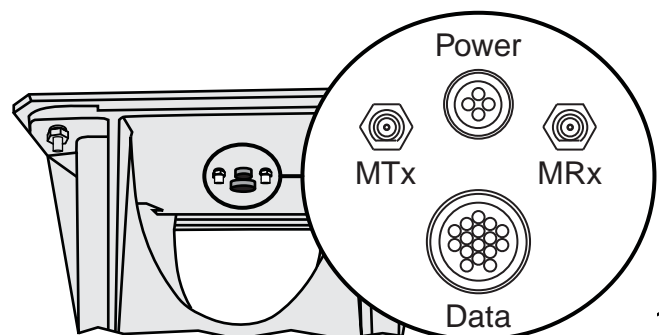

# 8 Mount the Antenna

Follow these steps to mount the antenna to the mounting surface.

- a. Place the antenna baseplate over the holes drilled in the mounting surface.
- b. Make sure the service hatch faces the stern of the vessel. Also make sure the forward arrow inside the baseplate points toward the bow and is parallel to the vessel's centerline (see Figure 20).
- c. Make sure the four holes in the baseplate line up with the four holes in the mounting surface.
- d. At each of the four baseplate mounting holes, place an M10 lock washer and flat washer on an M10 bolt and insert the bolt into the hole from below (see Figure 21).
- e. Tighten all four bolts until the four rubber feet on the baseplate are bottomed against the mounting surface and the foam seal is fully compressed. KVH recommends that you tighten the bolts to between 12 and 16 ft-lbs (16.2 and 21.7 N-m) of torque.

Figure 20: Forward Arrow in Antenna Baseplate

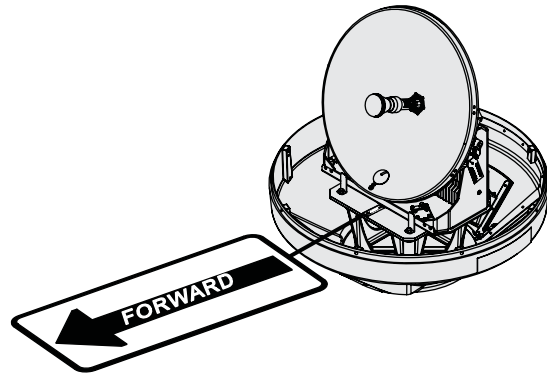
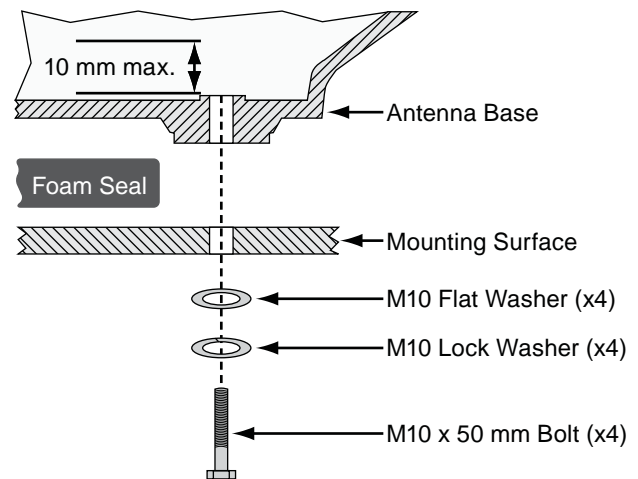

Figure 21: Mounting the Antenna (Side View)



# 9 Remove the Restraints

Inside the antenna, several shipping restraints prevent the antenna assembly from moving during shipment. Follow these steps to remove these shipping restraints.

- a. Using an 11/16" wrench and a 9/16" socket with 6" extension, remove the two 3/8" bolts, washers, and lock nuts securing the azimuth shipping restraints to the base of the antenna assembly (see Figure 22). Remove the "L" bracket restraints.
- b. Place a 3/8" flat washer (supplied in the kitpack) on the two 3/8" bolts that you removed in Step a. Reinstall the bolts and secure in place with the washers and lock nuts you removed in Step a (see Figure 23). These bolts secure the antenna assembly to the internal mounting platform.
- c. Using wire cutters, cut and remove the wire shipping restraint securing the reflector to the antenna frame (see Figure 24).
- d. Cut and remove the tie-wrap securing the antenna's LNB to the back of the reflector (see Figure 24).
- e. Reinstall the radome onto the antenna. Secure in place with the two #10-32 screws you removed in Step 6b, along with the six #10-32 screws supplied in the kitpack (see Figure 17 on page 10).
- f. Reattach the service hatch to the antenna's baseplate using the M4 screws you removed in Step 6a (see Figure 16 on page 10).
- g. Install a protective plastic cap (supplied in the kitpack) over each radome screw.

Figure 22: Removing the Shipping Restraint Brackets

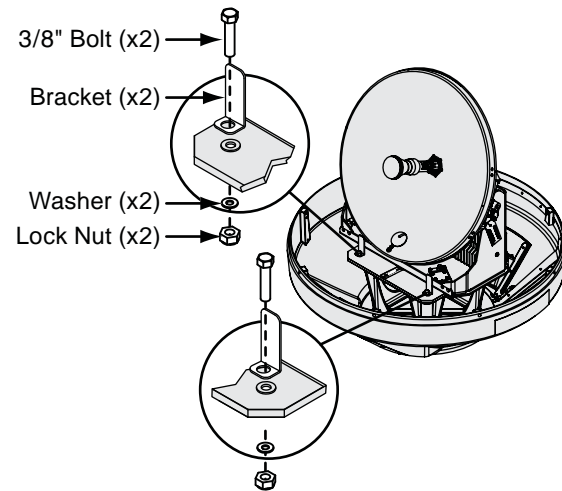

Figure 23: Reinstalling the Mounting Bolts

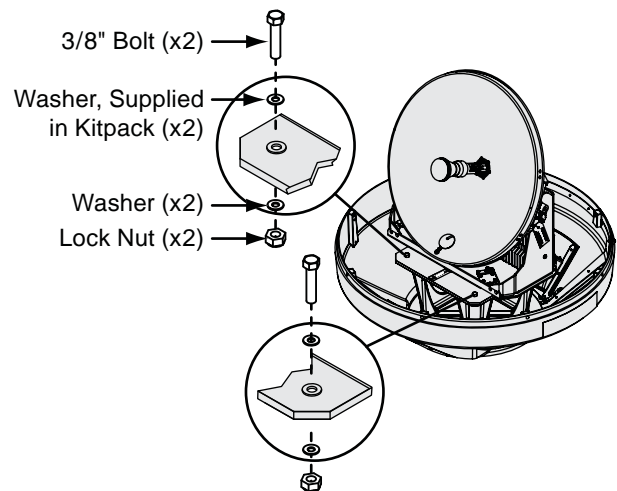
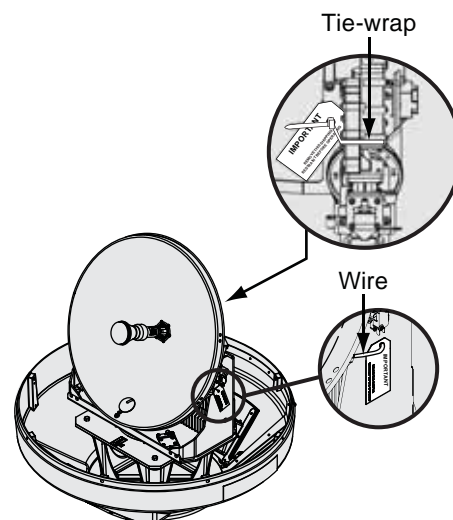

Figure 24: Removing the Wire and Tie-wrap Restraints



# 10 Wire the Belowdecks Units

## Wire the Antenna Cables

Follow these steps to connect the antenna to the control unit and the modem.

**NOTE:** A system wiring diagram is provided in Appendix A on page 29.

- First dress the data and power cables from the antenna. Strip back the insulation of each wire approximately 1/4" (6 mm) and gently twist each wire to ensure a good electrical connection.
- Find the terminal strip connector in the kitpack. Connect the antenna data cable to the terminal strip connector as shown in Figure 25.

**IMPORTANT!**

The diagram refers to wires by **body color/ stripe color**. For example, "Brown/White" means the brown wire with the white stripe.

- Connect the power cable from the antenna to the terminal strip connector as shown in Figure 25.
- Plug the terminal strip connector into the rear panel of the control unit (see Figure 26).
- Connect the RF coax cable labeled "RX" (connected to the antenna's MRx jack) to the "Rx RF" jack on the back of the modem (see Figure 27).
- Connect the RF coax cable labeled "TX" (connected to the antenna's MTx jack) to the "Tx RF" jack on the back of the modem.

**IMPORTANT!**

Be sure to terminate RF cables properly with type "F" connectors.

Figure 25: Antenna Power and Data Wiring

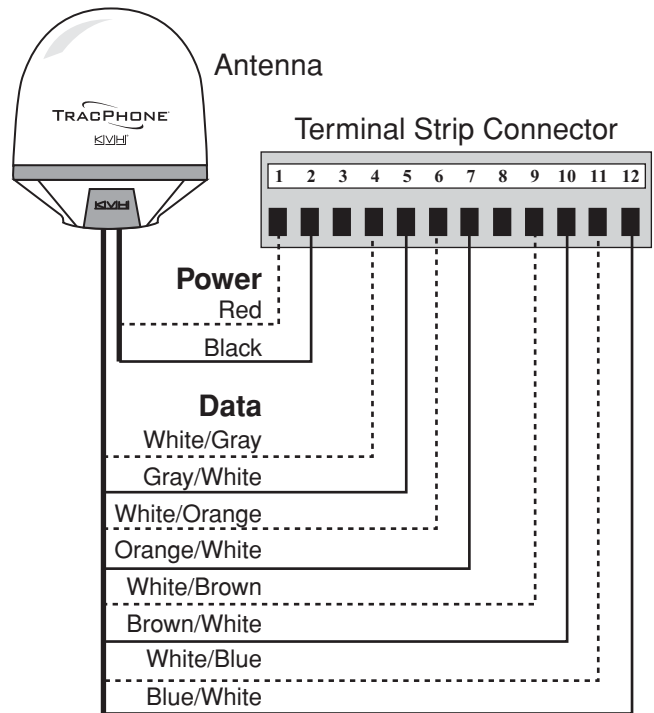

Figure 26: Antenna Power and Data Wiring

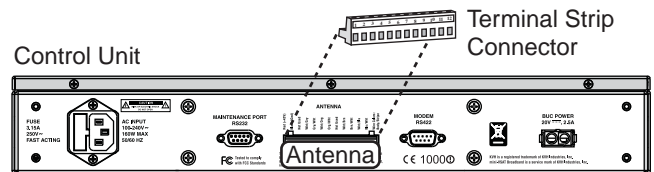
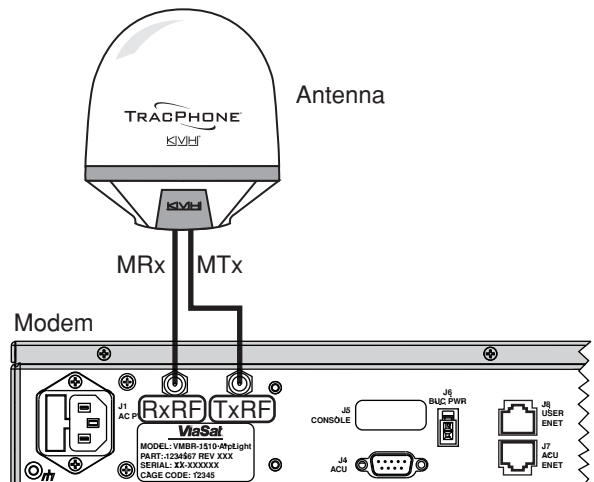

Figure 27: Antenna RF Transmit and Receive Wiring



# 10 Continued Wire the Belowdecks Units

## Wire the Control Unit to the Modem

Follow these steps to connect the control unit to the modem.

- Connect a serial data cable from the “Modem” jack on the control unit to the “ACU” jack on the modem (see Figure 28).
- Connect the BUC power cable from the “BUC Power” jack on the control unit to the “BUC Pwr” jack on the modem.

Figure 28: Modem Data and BUC Power Wiring

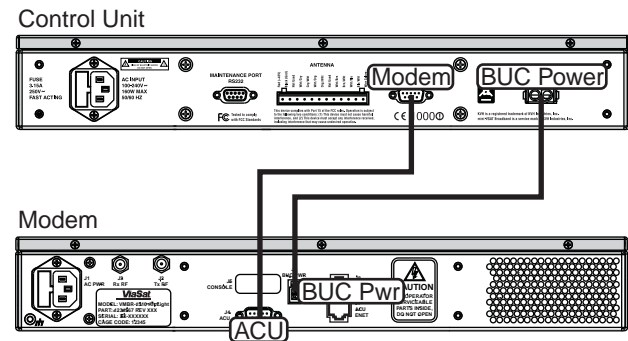

## Wire the Remote Service Module

Follow these steps to connect the remote service & support module to the control unit.

- Connect a serial data cable from the “Maintenance Port” jack on the control unit to the “Serial” jack on the remote service & support module. (see Figure 29).
- Make sure the cellular antenna is connected to the “Antenna” jack on the remote service & support module.

Figure 29: Remote Service & Support Module Wiring

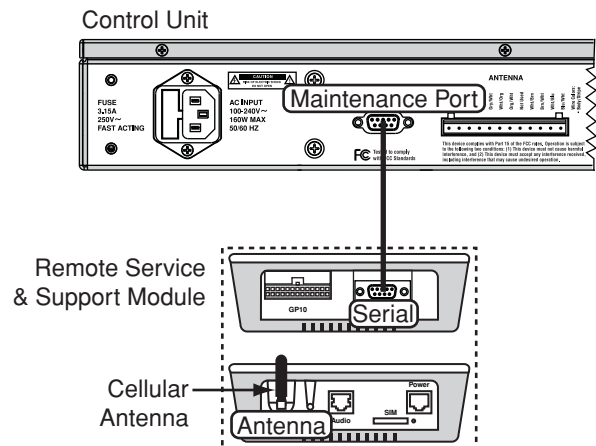

## Wire the Switch and MTA

Follow these steps to connect all LAN devices.

- Connect the supplied straight-through Ethernet cable from the “User ENet” jack on the modem to any port on the switch (see Figure 30).
- Connect a second straight-through Ethernet cable from any port on the switch to the “WAN” jack on the MTA.
- Connect the customer’s analog (not digital) phone(s), fax machine, and/or PABX to the desired RJ-11 “Phone” jack(s) on the MTA. Each jack is linked to a unique phone line.

**NOTE:** If the customer requires an enterprise-grade fax solution, install KVH’s optional UCH-250 Fax Server (KVH part #19-0520).

- For a wired Ethernet network, connect the customer’s computer(s) to any port(s) on the switch. For a wireless network, connect an access point (customer-supplied) to the switch (ports 1-4 support IEEE 802.3af devices).

Figure 30: Switch and MTA Wiring

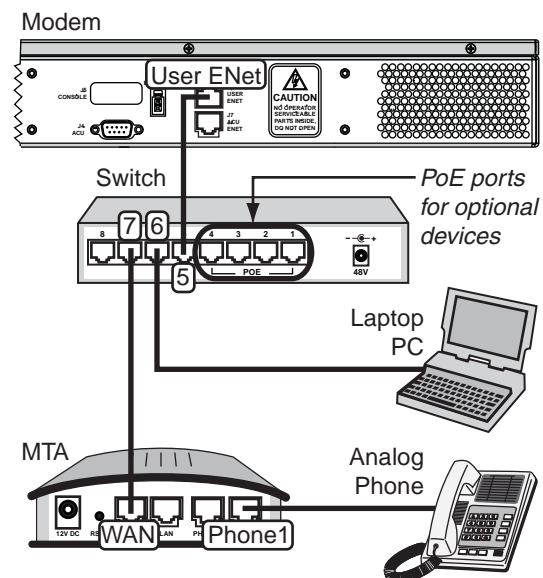

**NOTE:** The Ethernet and VoIP equipment supplied with the system might differ from those shown in this diagram.



# 11 Connect Power

Follow these steps to connect power to the TracPhone V7 system.

WARNING

The TracPhone system requires 3-wire single-phase AC power (hot, neutral, and ground). Voltage between hot-neutral and hot-ground should each measure between 100-240 VAC.

Some large ships use two-phase, split-phase, or delta power instead (3 wires: hot, hot, and ground; no neutral). In this case, voltage between hot-hot measures the proper voltage (100-240 VAC), while hot-ground measures only half the voltage (50-120 VAC). The TracPhone system cannot operate on this type of power. **Attempting to run the TracPhone system directly on two-phase, split-phase, or delta power will cause an unsafe floating ground condition, risking damage to the antenna and electric shock, potentially resulting in death.** In a floating ground condition, the difference between the equipment's chassis ground and the ship's ground can measure well over 100 volts, when it normally should not exceed 25 volts.

Therefore, if the vessel is limited to two-phase, split-phase, or delta AC power, or if there is a floating ground condition, you **MUST** use a suitable isolation transformer to supply single-phase power to the TracPhone system (see Figure 31).

- a. Before you begin, disconnect vessel power.
- b. Be sure the vessel is properly grounded in accordance with marine standards.
- c. Connect the control unit and modem to the supplied AC power strip using the adapter cables provided in the kitpack (see Figure 32).
- d. Strain-relieve all wires at the back of the control unit and modem by securing them to the attached strain-relief bracket(s) using tie-wraps. Leave enough slack for serviceability.

Figure 31: Single-Phase AC Power Input

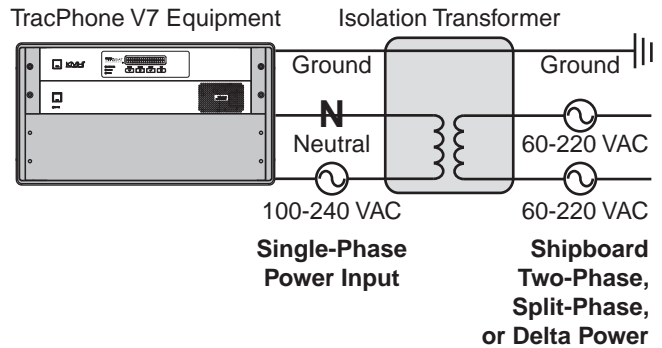

**NOTE:** Ground fault protection devices cannot detect faults behind an isolation transformer.

Figure 32: Power Wiring

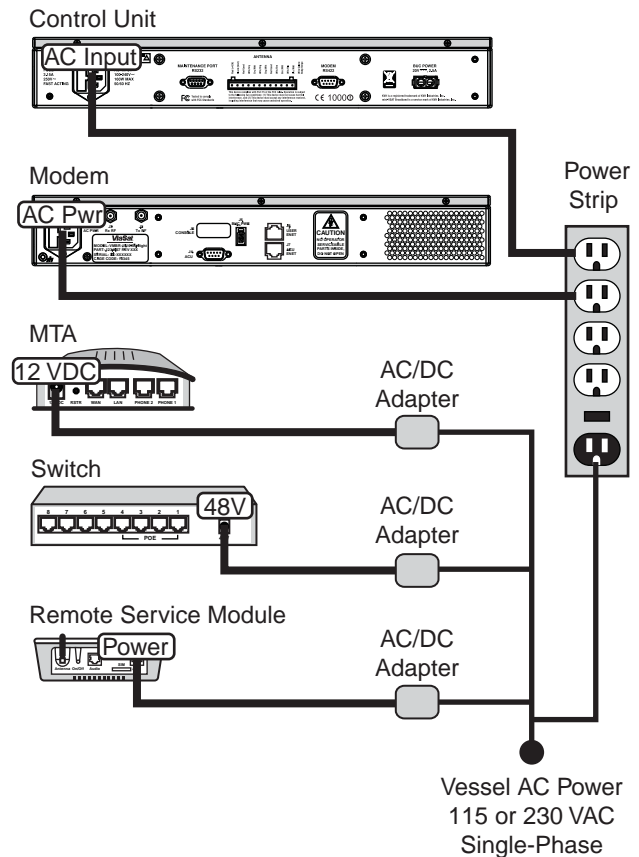

# 11 Continued Connect Power

---

- e. Connect the appropriate power cord (US or European) to the power strip. Then plug it into the vessel's 115 or 230 VAC supply.
- f. Connect the MTA, switch, and remote service & support module to AC power via their AC/DC adapters (see Figure 32 on page 16).

# 12 Configure the Computer(s)

Follow these steps to configure the user's computer(s) for a wired connection to the TracPhone V7. Once you have set up and tested a wired connection, you can configure a wireless connection (*wireless access point not supplied*).

## IMPORTANT!

Establishing a wireless connection onboard a steel vessel might require a special WAP and advanced networking expertise.

## IMPORTANT!

When setting up a wireless network, apply security settings, such as encryption, to protect the network from outside intrusion.

**NOTE:** The computer must have a network interface card installed and all cabling must be 100 Mbps fast Ethernet UTP CAT-5 with RJ45 connectors.

## Windows 7 or Vista

- Turn on the networked computer.
- From the Windows Control Panel, navigate to the **Network and Sharing Center**. You can find the control panel either through the Start menu or "My Computer."
- At the Network and Sharing Center window, double-click the **Local Area Connection** link (Windows 7) or **View Status** link (Windows Vista) for the Ethernet connection you are using for TracPhone V7.
- At the Local Area Connection Status window, click **Properties**. *This screen only displays if the computer is currently connected to a network.*
- At the Local Area Connection Properties window, select the **Networking** tab. Then select **Internet Protocol Version 4** and click **Properties** (see Figure 33).
- At the Internet Protocol Properties window, select **Obtain an IP address automatically** and **Obtain DNS server address automatically** (see Figure 34). Then click **OK**.
- At the Local Area Connection Properties window, click **OK**.

Figure 33: Windows 7/Vista - Local Area Connection Properties

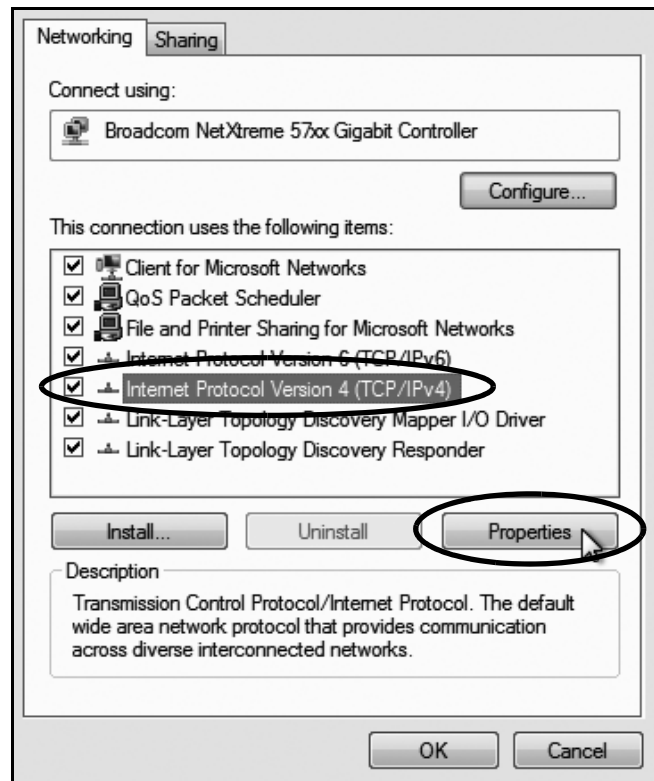
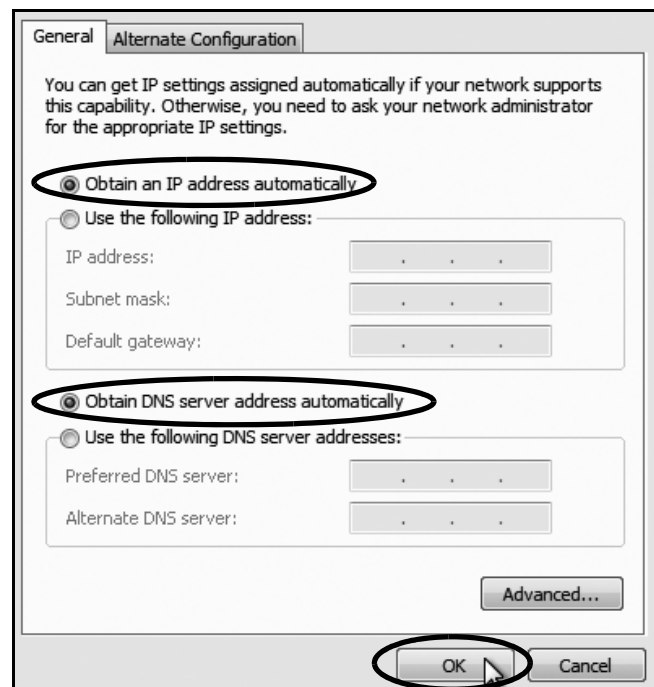

Figure 34: Windows 7/Vista - Internet Protocol Properties



# 12 Continued configure the Computer(s)

## Windows XP

- a. Turn on the networked computer.
- b. At the Windows Control Panel, double-click **Network Connections**. *You can find the control panel either through the Start menu or "My Computer."*
- c. At the Network Connections window, double-click the **Local Area Connection** icon for the Ethernet connection you are using for TracPhone V7.
- d. At the Local Area Connection Status window, select the **General** tab. Then click **Properties**. *This screen only displays if the computer is currently connected to a network.*
- e. At the Local Area Connection Properties window, select the **General** tab. Then select **Internet Protocol (TCP/IP)** and click **Properties** (see Figure 35).
- f. At the Internet Protocol (TCP/IP) Properties window, select the **General** tab. Then select **Obtain an IP address automatically** and **Obtain DNS server address automatically** (see Figure 36). Then click **OK**.
- g. At the Local Area Connection Properties window, click **OK**.
- h. Restart the computer.

Figure 35: Windows XP - Local Area Connection Properties

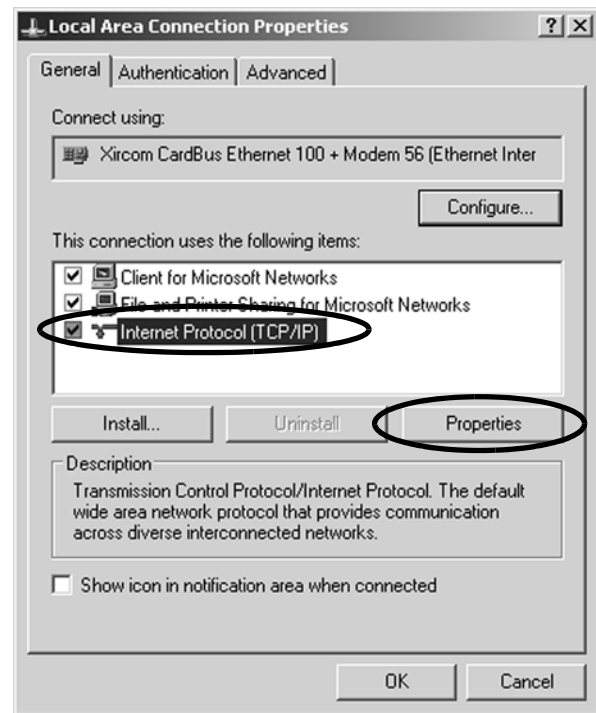
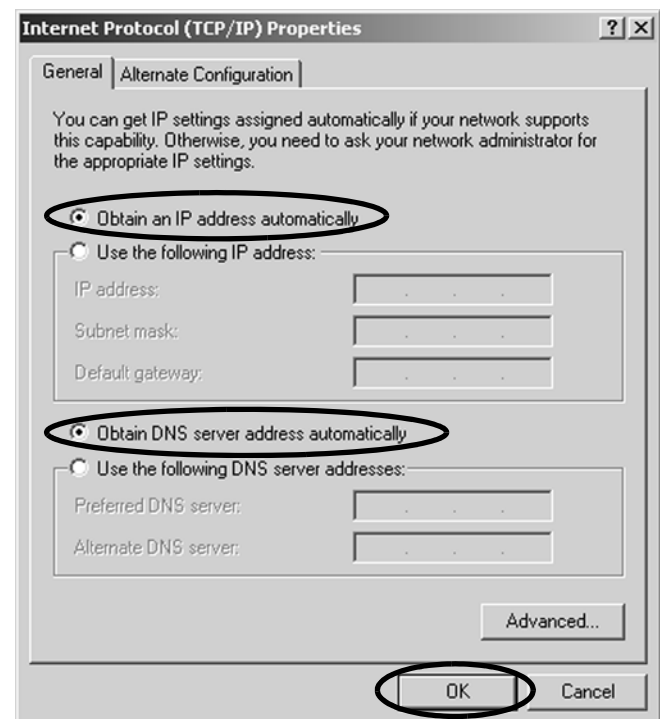

Figure 36: Windows XP - Internet Protocol (TCP/IP) Properties



# 12 Continued Configure the Computer(s)

## Macintosh OS X

- a. Turn on the networked computer.
- b. At System Preferences, click the **Network** icon.
- c. At the Network window (see Figure 37), select the following:
  - Show: **Built-in Ethernet**
  - Configure: **Using DHCP**
  - Leave all text boxes blank
- d. Network: Click **Apply Now**.
- e. Restart the computer.

Figure 37: Macintosh OS X - Network Preferences



# 13 Turn On the System

Follow these steps to turn on the TracPhone V7 system for the first time.

## **IMPORTANT!**

Double-check all of your wiring before continuing. If wiring is incomplete or incorrect, electronics may become damaged when you apply power.

- a. Ensure the antenna has a clear, unobstructed view of the sky.
- b. Apply vessel power to the TracPhone system, including the switch, MTA, and remote service & support module.
- c. Turn on the power switch on the front of the the modem (see Figure 38). The button's light should illuminate green.
- d. Turn on the power switch on the front of the control unit (see Figure 38). The button's light should illuminate green.
- e. Wait 5 minutes for system startup.
- f. Verify that the status lights on the control unit and modem (see Figure 39) exhibit the following conditions:
  - **Control Unit:** Lit green
  - **Antenna:** Lit or flashing green
  - **Modem:** Lit or flashing green
  - **Status:** Any condition except off
- g. Verify that the status lights on the MTA and switch indicate a normal condition. Refer to the MTA and switch manuals for details.

Figure 38: Power Switches

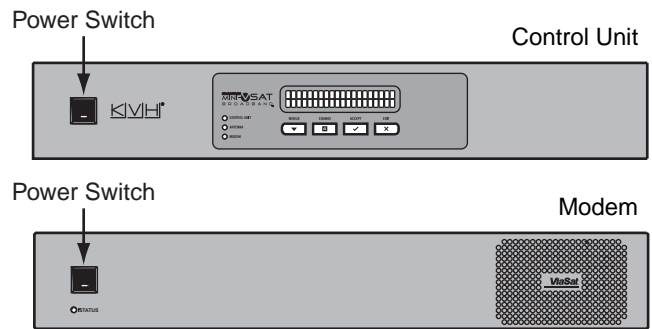
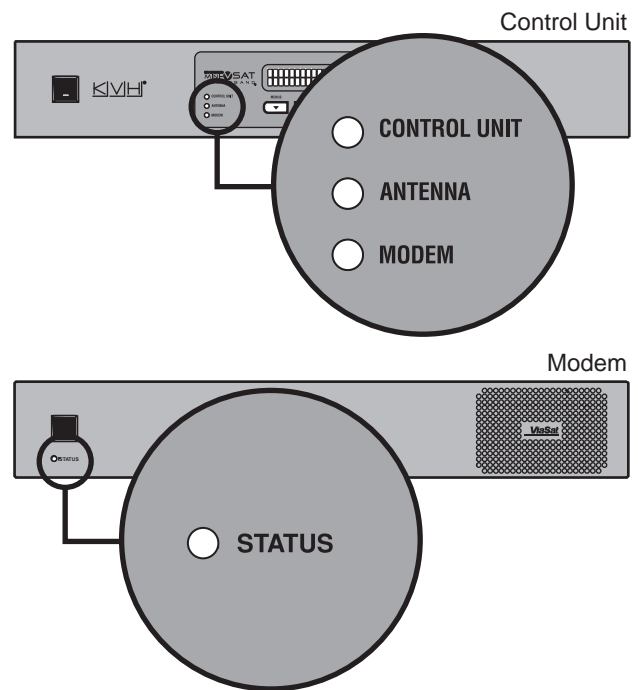

Figure 39: Status Lights



# 14 Update the System Software

If Necessary

Follow these steps to ensure the latest software is installed in the TracPhone V7 system.

- At the control unit, press **MENUS** until the display shows “ANTENNA STATUS” (see Figure 40). Then press **ACCEPT**.
- Press **MENUS** until the display shows “ANTENNA MAIN BOARD.” Note the reported software (SW) version.
- Press **MENUS** to view the software versions for the RF board, AZ/EL motor, skew motor, and control unit. Note all of these versions.
- Compare the software versions you just noted on the control unit with the latest versions listed in the TPV7 Flash Update Wizard’s Release Notes.

**NOTE:** Before using the TPV7 Flash Update Wizard, be sure to check for updates to ensure it has all of the latest software files (Internet access required).

- Use the TPV7 Flash Update Wizard to update any older versions of software in the TracPhone V7 system. Refer to the Wizard’s Help menu for complete details (see Figure 41).

Figure 40: Software Versions Displayed on the Control Unit

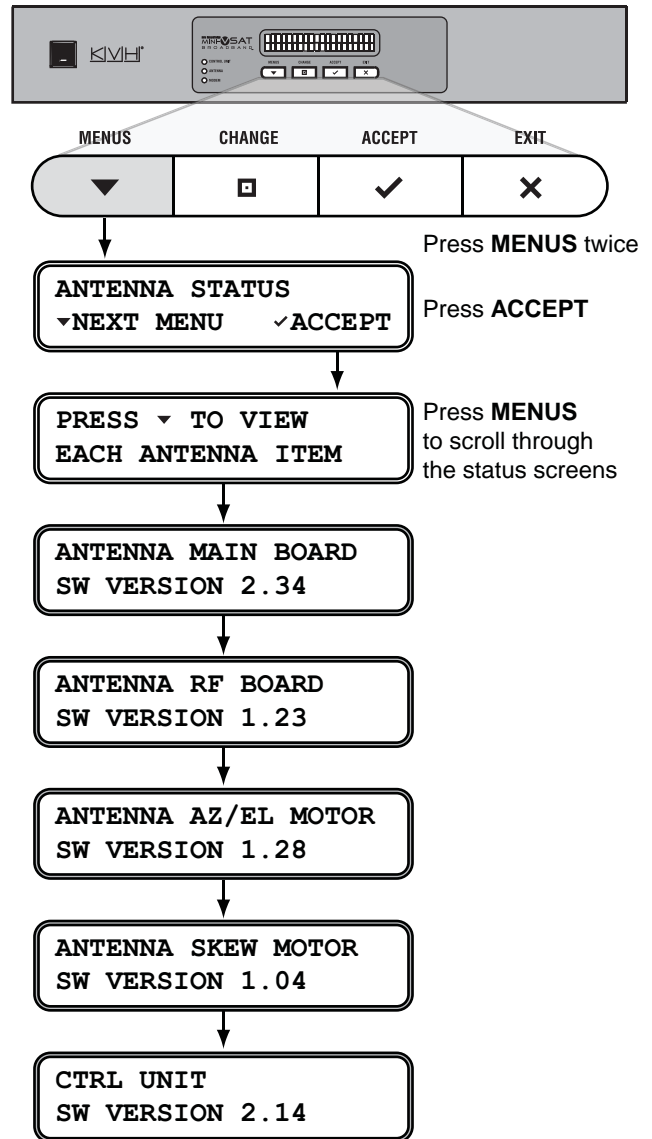

Figure 41: TPV7 Flash Update Wizard Help Menu



# 15 Set Up RF Hazard Zones

Optional

To prevent exposure to RF energy, which might be harmful to people who stand within 36 feet (11 meters) of the antenna, you can configure up to two RF radiation hazard zones for areas where crew and/or passengers frequent (see Figure 42). The system will disable the transmitter whenever the antenna is pointing within one of these zones.

Follow these steps to set up an RF hazard zone.

- Determine the necessary azimuth range for the RF hazard zone(s). You will need to enter, in clockwise order, beginning and ending azimuths (>4° apart) **relative to the antenna's forward arrow**, which should be pointing toward the bow (see Figure 43).
- At the control unit, press **MENU** until the display shows "CONFIGURATION." Then press **ACCEPT**.
- Press **MENU** until the display shows "SET HAZARD ZONE."
- Press **CHANGE** until the display shows "SET HAZARD ZONE = YES." Then press **ACCEPT**.
- At "ZONE 1," press **CHANGE**. A cursor appears under the first number in the azimuth range for RF hazard zone #1.
- Press **CHANGE** until the number is set to the first digit of the beginning azimuth for the first hazard zone (*enter a zero if < 100°*).
- Press **ACCEPT**. The cursor moves to the next number.
- Repeat steps f and g to set the remaining digits of the desired RF radiation hazard zone. Then press **ACCEPT**.
- At "Zone 2," repeat steps e-h to set the range for the second RF hazard zone, if desired.
- At "XMT IN ZONES," verify that the display shows "XMT IN ZONES = NO." Then press **MENU**.
- Press **EXIT** to exit the menu.

**NOTE:** For more details, refer to the Configuration section of the User's Guide.

Figure 42: Example of an RF Radiation Hazard Zone

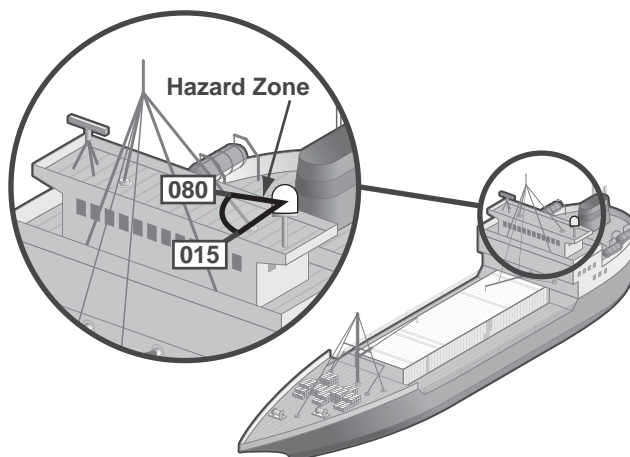

Figure 43: Azimuths Relative to Antenna's Forward Arrow

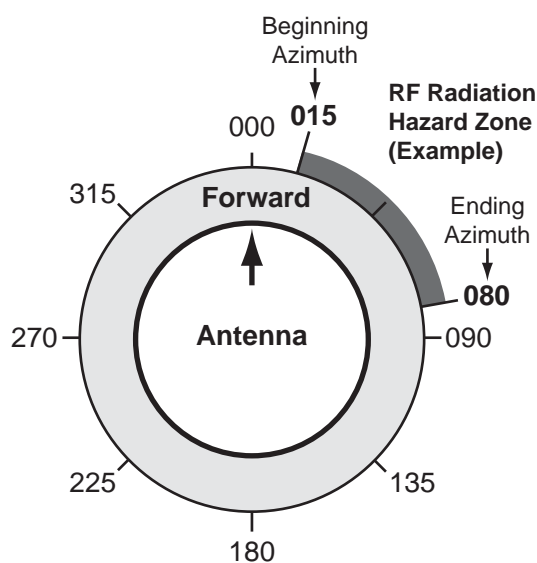
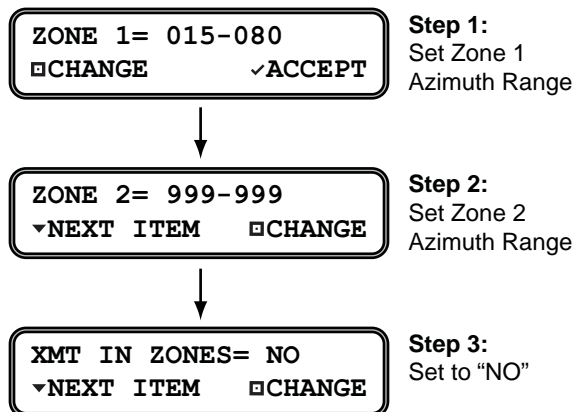

Figure 44: Setup Process for RF Hazard Zones





# 16 Test the System

Now that you have installed the system, you can test the system to verify it is ready for customer delivery. Follow these steps to test the system for proper operation.

- a. Ensure the antenna has a clear, unobstructed view of the sky.
- b. With the TracPhone system powered on, restart the networked computer(s).
- c. Verify that the antenna is tracking the service satellite and the modem is connected to the mini-VSAT Broadband service, as indicated by the control unit screen shown in Figure 45. If an error appears, refer to the Troubleshooting section of the *User's Guide*.

### IMPORTANT!

Once the system is online, do not turn it off for 30 minutes to allow the modem to download the latest configuration files via the satellite. If the modem is unable to connect, you may upload the files manually via the modem's web interface. Details are available to technicians on the KVH Partner Portal.

- d. If the customer has activated the TracPhone system for mini-VSAT Broadband service, verify that the system can access the Internet by entering any common website address (URL) into the browser.
- e. If the customer has activated the TracPhone system, also verify that you can place a voice call. First make sure the MTA's "VOIP" light is lit green (see Figure 46). Then, using any telephone connected to the MTA, place a call to someone on a terrestrial or cellular network and ask that person to call you back at the customer's number.
- f. Even if the customer has not yet activated the TracPhone system for mini-VSAT Broadband service, you can still check the modem's communications to the land-based hub. Open the web browser on any networked computer and enter the following address to access the Welcome page: <http://208.83.165.11/mbbtest>. Verify that the Welcome page appears in the browser (see Figure 47).

Figure 45: Good Service Connection Indicated on Control Unit LCD

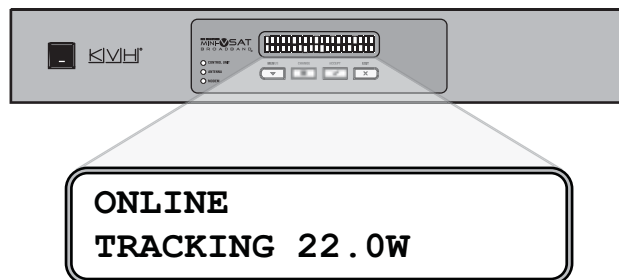

**NOTE:** Satellites will vary depending on your location.

Figure 46: MTA Status Lights

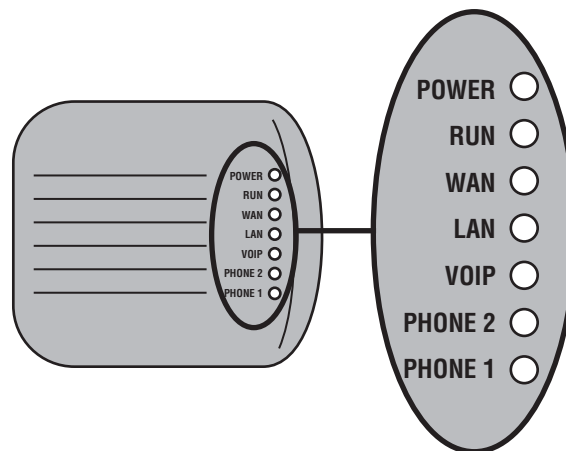
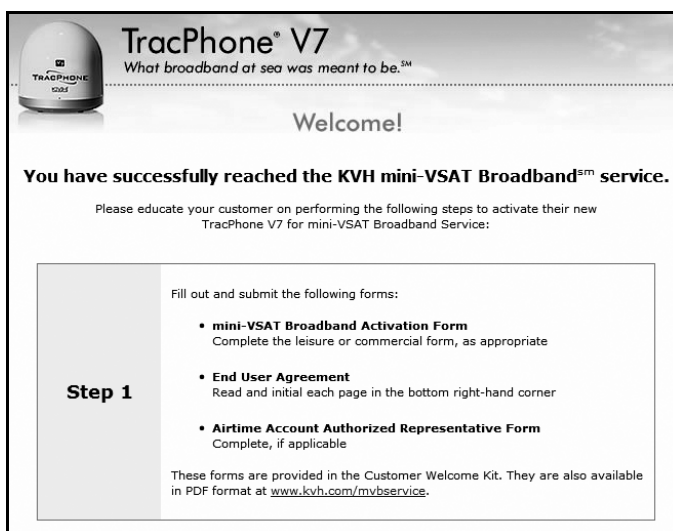

Figure 47: Welcome Page for Testing



# 16 Continued Test the System

- g. Open the web browser on any wired (not wireless) networked computer and enter the following address to access the modem's web interface: **http://192.168.0.1**
- h. Under "Forward Link" on the General Status page, make sure **Eb/No is at least 2 dB** (see Figure 48).

***NOTE:** Refer to the User's Guide for details about the other status information that is available on this web page.*

Figure 48: General Status Page Via Modem Web Interface

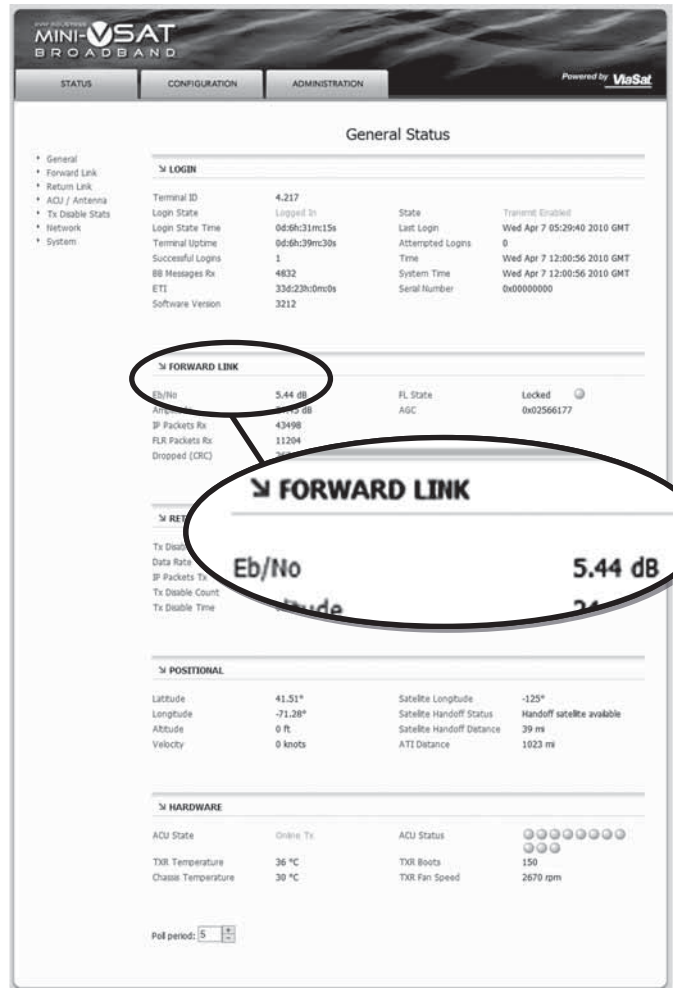

# 17 Educate the Customer

The installation is complete! Before you leave the vessel, enter the system serial numbers on the first page of the *User's Guide*, give the Welcome Kit to the customer, and review the following with the customer:

- Advertised data speeds and reasons why speeds may decrease at times (refer to Section 15 of the End User Agreement)
- Voice service and all associated long-distance charges (refer to the Airtime Rate Sheet)
- Fair Access Policy: streaming video and peer-to-peer file sharing are prohibited (refer to Sections 44-45 of the End User Agreement)

Also explain how to use the system and be sure the customer understands the following:

- **The antenna transmits RF energy that is potentially harmful.** Whenever the system is powered on, make sure everyone stays more than 36 feet (11 meters) away from the antenna within its 5-80° look angle (see Figure 50). No hazard exists directly above the antenna and anywhere below the antenna's mounting plane.
- Keep the radome installed on the antenna at all times. The radome protects the antenna's moving parts from wind, rain, and debris.
- The antenna must have a clear view of the sky to communicate via satellite. Common causes of blockage include masts, trees, buildings, and bridges (see Figure 51).
- Clean the antenna regularly. Dirt buildup on the radome can affect communications. Heavy rain or snow may also temporarily interrupt communications.
- The vessel must be located within the coverage area of the satellite. To view a coverage map, visit [www.kvh.com/minisatmap](http://www.kvh.com/minisatmap).
- The system must be activated for mini-VSAT Broadband service. For activation details, refer to the Activation Checklist located in the Welcome Kit or on the web at [www.kvh.com/mvbservice](http://www.kvh.com/mvbservice).

Figure 49: Customer Welcome Kit



Figure 50: Safe Distance to Avoid Risk of RF Radiation Exposure

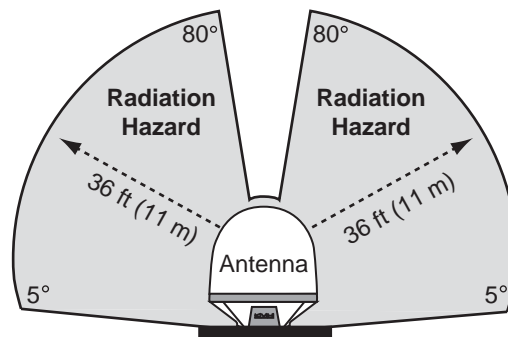
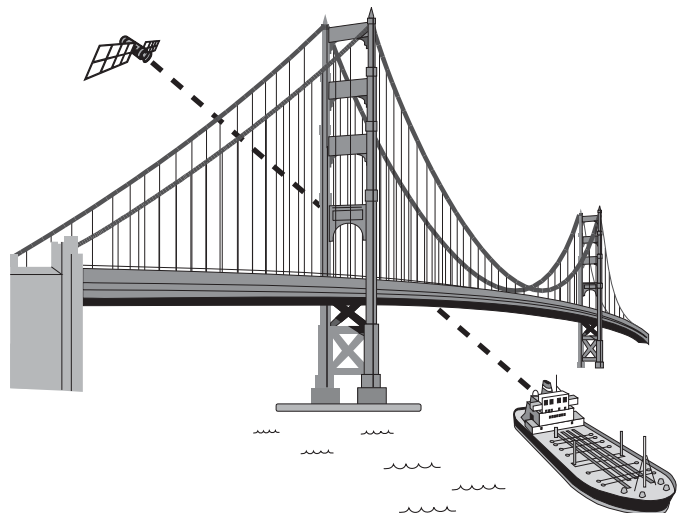

Figure 51: Example of Satellite Blockage



# Appendices

This section provides a system wiring diagram and supplemental instructions for terminating an LMR-400-75 cable.

---

## Contents

A. Wiring Diagram.....	29
B. Terminating LMR-400-75 Cables.....	30

# A Wiring Diagram

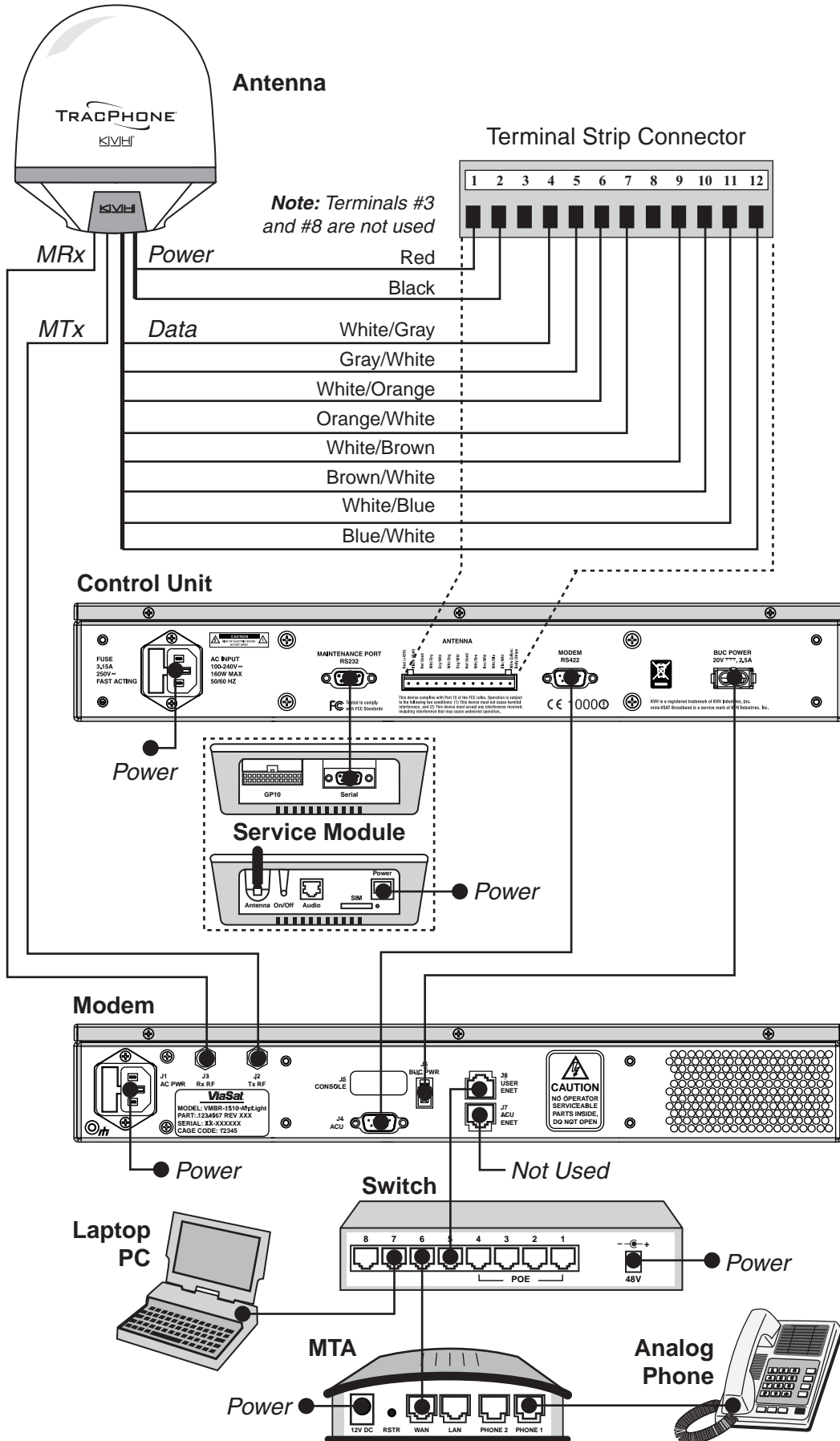

# B Terminating LMR-400-75 Cables

## Appendix

These instructions explain how to terminate an LMR-400-75 RF cable with an EZ-400-FMH-75 “F” connector using the tools from the TK-400EZ-75 tool kit. For more detailed instructions, refer to the Times Microwave website ([www.timesmicrowave.com](http://www.timesmicrowave.com)).

1. Using the CCT-01 cutting tool, cut the cable evenly (see Figure 52).
2. Since cutting the cable can deform the end, gently round the end of the cable using a pair of needle-nose pliers (see Figure 53). Also make sure the center conductor is centered within the cable.
3. Place the heat shrink sleeve and metal ferrule onto the cable (see Figure 54).
4. Insert the end of the cable into the #1 end of the ST-400EZ stripping tool (see Figure 55). Then rotate the tool clockwise around the cable until the tool turns easily. The end of the cable should now be stripped to expose the center conductor.

Figure 52: Cutting the Cable



Figure 53: Reshaping the Cable

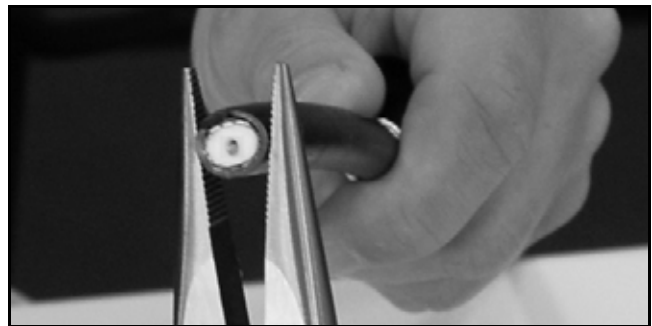

Figure 54: Placing the Heat Shrink Tubing and Ferrule



Figure 55: Stripping the End to Expose the Center Conductor



# **B** Continued Terminating LMR-400-75 Cables

5. Using a utility knife, carefully remove any residual plastic from the center conductor, if necessary (see Figure 56).
6. Insert the end of the cable into the #2 end of the ST-400EZ stripping tool (see Figure 57). Then rotate the tool clockwise around the cable until the tool turns easily. This removes the cable jacket from the end of the cable, exposing the braid and dielectric (see Figure 58).
7. Using the DBT-02 tool, deburr and chamfer the center conductor (see Figure 59). Avoid nicking the aluminum tape covering the dielectric.

Figure 56: Removing Plastic Residue



Figure 57: Stripping the Cable Jacket

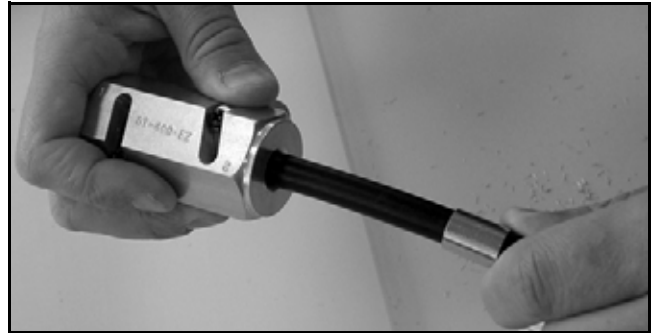

Figure 58: Cable Stripped, Exposing Dielectric



Figure 59: Deburring the Center Conductor



# B Continued Terminating LMR-400-75 Cables

8. Gently flare the braid with your fingers (see Figure 60).
9. Insert the end of the cable into the connector body until the dielectric is firmly seated inside the connector (see Figure 61). Be sure all braid wires remain on the outside of the connector.
10. Trim any excess braid (see Figure 62), if necessary. The braid should assemble flush to within  $1/16$ " (1.6 mm) of the connector shoulder.
11. Slide the ferrule over the braid until it is flush against the connector shoulder (see Figure 63).

Figure 60: Flaring the Braid



Figure 61: Pushing On the Connector

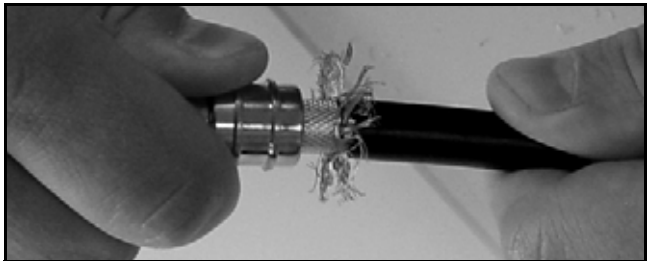

Figure 62: Trimming the Braid

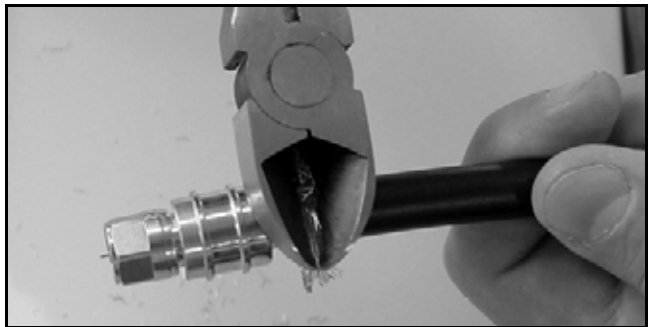
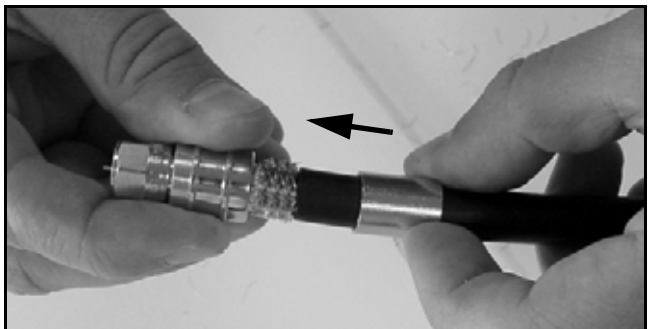

Figure 63: Sliding the Ferrule Over the Braid





# B Continued Terminating LMR-400-75 Cables

12. Using an appropriate crimp tool (either the CT-400/300 or the HX-4 with Y1719 dies), crimp the ferrule in place (see Figure 64). Crimp as close to the connector body as possible.
13. Crimp the ferrule again, but further back from the connector. However, be careful not to crimp the cable jacket.
14. Slide the heat shrink sleeve over the connector body and heat it to compress it into place (see Figure 65). When you are done, the heat shrink should extend from the rear of the connector to the cable jacket. This forms a weather-tight seal.
15. Using a multimeter or similar device, check the continuity of the cable.

Figure 64: Crimping the Ferrule onto the Cable

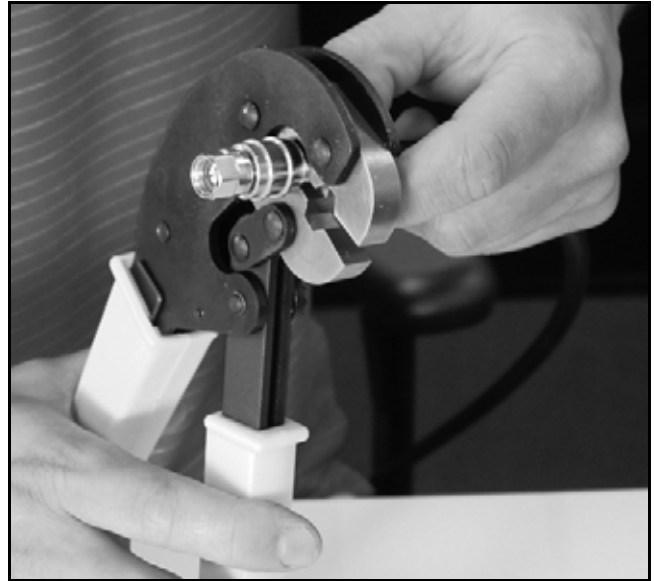

Figure 65: Applying the Heat Shrink Tubing





[www.kvh.com](http://www.kvh.com)

**KVH Industries, Inc.**  
Middletown, RI U.S.A.  
Tel: +1 401 847 3327  
Fax: +1 401 849 0045  
E-mail: [info@kvh.com](mailto:info@kvh.com)

**KVH Europe A/S**  
Kokkedal, Denmark  
Tel: +45 45 160 180  
Fax: +45 45 160 181  
E-mail: [info@kvh.dk](mailto:info@kvh.dk)

**KVH Norway AS**  
Horten, Norway  
Tel: +47 33 03 05 30  
Fax: +47 33 03 05 31  
E-mail: [commboxsales@kvh.com](mailto:commboxsales@kvh.com)

**KVH Singapore**  
Singapore  
Tel: +65 6829 2343  
Fax: +65 6829 2121  
E-mail: [infokvhsingapore@kvh.com](mailto:infokvhsingapore@kvh.com)